

EnerLog User Manual

SHENZHEN ATESS POWER TECHNOLOGY CO.,LTD

1st Floor of Building 3 at Sector B and 3rd Floor of Building 9, Henglong Industrial Park, Shuitian,
Baoan District, Shenzhen

www.atesspower.com

Revised date:2022-04-13

CONTENT

1 About the user manual

- 1.1 Manual description
- 1.2 Applicable personnel

2 Product description

- 2.1 Device overview
- 2.2 Packing info
- 2.3 Function introduction

3 Installation and Connection

- 3.1 Installation environment
- 3.2 Installation method
- 3.3 Connect to device

4 EnerLog internal page parameter setting

- 4.1 IP access method
- 4.2 Internal page access
- 4.3 Datalogger status view
- 4.4 Add and delete device
- 4.5 Baud rate setting
- 4.6 Network communication

5 Upload data to server

- 5.1 Registration and login
- 5.2 Create new power plant
- 5.3 Add EnerLog to server
- 5.4 Check the monitoring data

6 Device Maintenance

- 6.1 Reset EnerLog
- 6.2 Common faults and troubleshooting
- 6.3 Maintenance

7 Technical specifications

- 7.1 EnerLog specification

8 Contact us

1 About the user manual

1.1 Manual description

This manual is meant to provide detailed product information and installation instruction for users of EnerLog that produced by Shenzhen ATESS Power Technology Co., Ltd. (hereinafter referred to as ATESS) .

Please read this manual carefully before using this product, and store this manual in a place that is convenient for installation, operation, and maintenance personnel.

ATESS will not notify users of any changes to this manual. The contents of the manual will be continuously updated and revised, and it is inevitable that there will be slight discrepancies or errors with the actual products. Users purchased products please kind contact your local dealer or visit our website: www.atesspower.com to download the latest version of the manual to obtain information.

1.2 Applicable personnel

This manual is for professional technicians who install, commission, and maintain the EnerLog and for users who perform daily operations. This manual does not include electrical connections for inverters, combiner boxes, weather stations, smart meters, and anti-reflux devices, as well as related precautions. If necessary, please refer to ATESS' corresponding user manual or instruction.

2 Product description

2.1 Device Overview

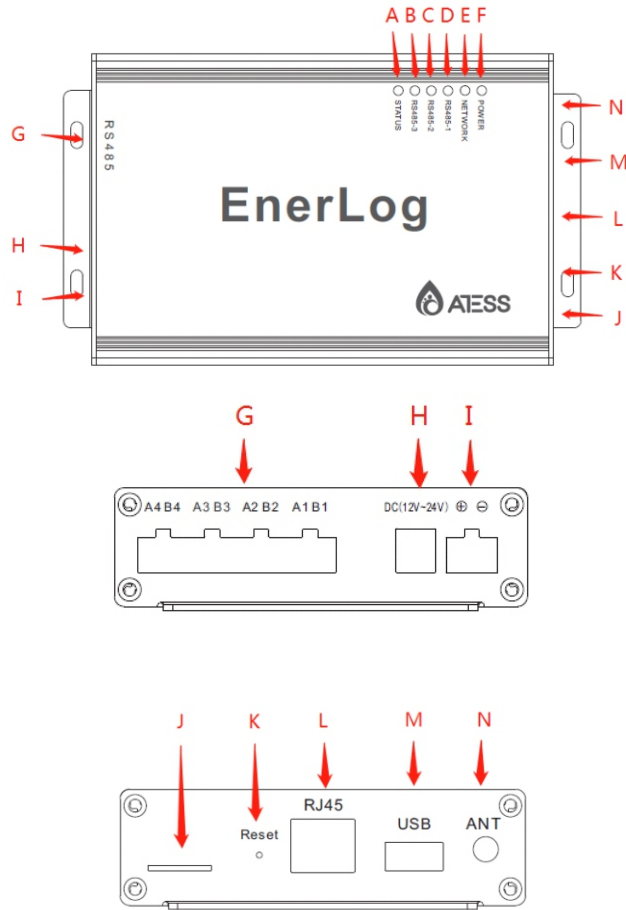

2.1.1 Interface

The interface of EnerLog, as shown in figure 2-1 above.

The functional description of each interface is shown in table 2-1.

Item	Name	Function
G	Rs485	4 RS485 channels, 1-3 can monitor the equipment, the 4th is the debugging channel.
H	Power interface 1	12V power adapter interface to provide working power.
I	Power interface 2	Backup power input port, see 3.2.1 for details
J	Card slot	Flow card socket (not yet this function)
K	Reset	Reset button: Long press for 4 seconds to restart EnerLog, long press for 10 seconds to restore factory settings.
L	Rj45	Cable interface
M	USB	USB interface: local upgrade EnerLog
N	ANT	Antenna interface (not available yet)

Table 2-1

2.1.2 Indicator status description

EnerLog has a total of 6 LED lights, through which the running status of EnerLog can be displayed.

Item	Name	Function
A	STATUS LED	System status light Fast flashing: program upgrade Interval flashing: normal operation LED off: abnormal operation
B	RS485-3 LED	Monitoring device data indicator, the number of periodic flashing represents the number of devices communicating normally with the RS485-3 channel and EnerLog.
C	RS485-2 LED	Monitoring device data indicator, the number of periodic flashing represents the number of devices communicating normally with the RS485-2 channel and EnerLog.
D	RS485-1 LED	Monitoring device data indicator, the number of periodic flashing represents the number of devices communicating normally with the RS485-1 channel and EnerLog.
E	NETWORK LED	Network indicator The off state means that it is not connected to the network normally; The steady state indicates that the network is connected normally.
F	POWER LED	Power Indicator Steady on: power supply is normal Off: Abnormal power supply

Table 2-2

2.2 Unpacking

2.2.1 Packing List

EnerLog and accessories can be found as below figure 2-2:

Item	Name	Amount
1	EnerLog	1 pc
2	12V power adapter	1 pc
3	RS485 and power supply interface 2 lock wire terminal	5 pcs
4	EnerLog user manual	1 pc
5	Network cable (1 meter)	1 pc
6	ATESS certificate	1 pc

Table 2-4

2.2.2 Serial No. and Check Code

EnerLog's serial number (SN) is a code consisting of letters and numbers affixed on the EnerLog outer package and on the EnerLog case. The check code (CC) is a 5-digit code consisting of letters and numbers affixed on the EnerLog outer package and on the EnerLog case. The serial number and check code of each EnerLog are unique and are used to identify the individual EnerLog. When uploading EnerLog data to the web server, you need to add EnerLog to the server by adding the serial number and the verification code corresponding to the serial number. The serial No. and 'check code' corresponding to register on the server are needed.

2.3 Function Introduction

EnerLog supports network communication, and can connect with cloud server through wired WLAN. Upload the monitored data to the server of ATESS, and then access the server's domain name to realize industrial common communication mode RS485. It also supports wired communication to monitor, set slave devices and perform online upgrades on devices. By accessing EnerLog's internal IP address, you can enter the internal page for parameter setting, device adding and viewing (please refer to section 4.4).

EnerLog monitors the devices through RS485.

3.1 Installation environment

EnerLog installation environment and communication requirements for other devices:

- (1) Indoor installation, temperature environment $-25^{\circ}\text{C} \sim 55^{\circ}\text{C}$, avoid humidity and direct sunlight.
- (2) The maximum communication distance of wired RS485 is 500m, and attention should be paid to prevent interference.
- (3) The length of the network cable between the router should not exceed 1000m.

3.2 installation method

3.2.1 Installation

The installation steps are as follows:

- (1) Install EnerLog on a vertical or horizontal surface.
- (2) Connect the connection line between the RS485 interface on the EnerLog and the RS485 interface on the device (for details, please refer to 3.3.1 below).
- (3) Communication method
 1. Standard version: Connect the network cable.
 - (4) Power connection selection (choose one of the methods to connect to the power supply)
 1. EnerLog distributes a set of DC12V output power adapters and conversion plugs with five standards in China, Britain, the United States, Europe and Australia to adapt to the socket standards of different countries.
 2. EnerLog is equipped with a 12V ~ 24V DC power input port, and the positive and negative poles need to be correctly connected.

3.3 Connect with device

EnerLog can communicate with energy storage inverters, BMS and other equipment to achieve the purpose of data collection.

3.3.1 RS485 cable connection

1. EnerLog (master) and device (slave) communicate through RS485 wired connection. The 485-A on the RS485 port of the device corresponds to A1, A2 or A3 on the EnerLog 485 port, and the 485-B on the RS485 port corresponds to B1, B2 or B3 on the EnerLog 485 port. The following is a schematic diagram of the connection between EnerLog and the inverter:

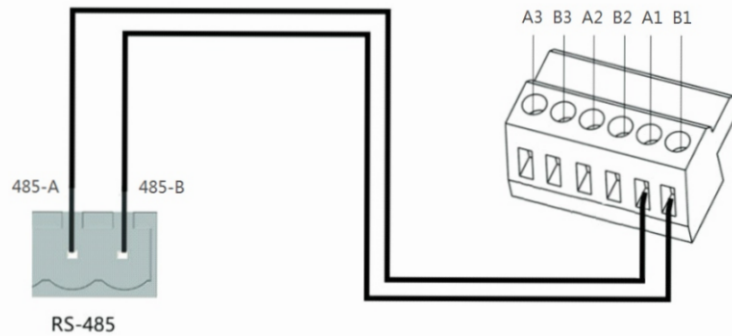

The functions of the A1B1, A2B2, and A3B3 channels are the same.

2. The inverter and the inverter are connected to the EnerLog through the RS485 line parallel connection, and the RS485 wired communication connection is adopted. The EnerLog can stably monitor up to 60 devices (each RS485 channel connects 20 devices).

3. Other 485 communication equipment such as: BMS, combiner box, etc., the connection method is the same as that of the inverter.

4. Notice:

(1) 1. The inverter and the inverter are connected to the EnerLog through the RS485 cable in parallel, using the RS485 wired communication to connect, the EnerLog can stably monitor a maximum of 60 devices (each RS485 channel is connected to 20 devices).

(2) Among the three 485 channels of EnerLog, channel 1 and 2 are connected with 120Ω matching resistors. So when one or more inverters are connected to EnerLog, one of the inverters performs 485 communication, one inverter must be connected to a 120Ω matching resistor to avoid affecting the communication (in one channel of 485, only one of multiple inverters can be connected to a matching resistor, and multiple inverters cannot be connected to a matching resistor at the same time), it is recommended to connect the matching resistor to the farthest inverter. 3 channels are not connected with matching resistors and are dedicated channels for electricity meters.

(3) Environmental detectors, combiner boxes and other equipment must be manufacturers designated by ATESS, otherwise monitoring cannot be achieved.

4 EnerLog Internal Page parameter setting

Precautions for configuration page operation:

(1) If the interface is not refreshed for a long time after clicking save when adding a device, please power off the collector and restart it. Re-enter this page after restarting, click "device status" to check whether the last operation was successful.

(2) When configuring the parameters of the corresponding function, you only need to configure the parameters of the corresponding function according to the above method, and do not modify the other parameters that cannot be made.

4.1 IP access method

It is recommended to use EnerLog with a router. EnerLog uses a router to access the Internet by default, so the first time you log in to the internal EnerLog page, you need to search for the IP address through the router backend to log in.

4.1.1 Dynamic IP login

1. Connect the PC and EnerLog to the same router so that they are in the same LAN.
2. Find the IP address of EnerLog

Take the H3C router as an example: Go to the router's management page, click "DHCP Server→Server List", and find the client name that is the same as EnerLog's serial number SN. This IP is the IP address assigned to EnerLog by the router.

序号	MAC地址	IP地址	主机名	绑定
1	50:88:18:E0:57:19	192.168.60.2	BAKFB02000-E05719	<input type="checkbox"/>
2	D0:AB:D5:0A:D4:44	192.168.60.3	DESKTOP-97VCIV6	<input type="checkbox"/>
3	10:63:C8:67:FC:4B	192.168.60.5	DESKTOP-35J0URG	<input type="checkbox"/>
4	D4:6A:6A:C8:8D:81	192.168.60.7	WIN-5G776Q6OOP	<input type="checkbox"/>

Note: The router must enable the DHCP function, otherwise the IP address cannot be assigned automatically.

3. Enter EnerLog's IP address in the browser to enter EnerLog's internal page.

4.1.2 Static IP login

When EnerLog uses a static IP to access the Internet, you need to use a static IP to log in to the internal page.

1. Connect the computer and EnerLog directly with a network cable.
2. On the computer "Network and Sharing Center" page, modify the computer's IP address and EnerLog's IP address to be in the same network segment.

(1) For example, if the static IP address set by EnerLog is 192.168.0.2, then the computer IP address can be set as:

使用下面的 IP 地址(S):

IP 地址(I):	192 . 168 . 0 . 5
子网掩码(M):	255 . 255 . 255 . 0
默认网关(G):	192 . 168 . 0 . 1

Note: no need to set DNS server address

3. After the computer IP setting is completed, enter the IP address of EnerLog on the computer browser page to access the internal page.

4.2 Login to the internal page

Before access, check whether the communication cable between the devices is firmly connected. After the check is correct, you can enter the EnerLog IP address in the browser to enter the internal EnerLog page.

Note: EnerLog and the computer must be in the same network segment, otherwise the internal page cannot be accessed.

1. Find the IP address of EnerLog in the router, and enter the IP address in the web address of the browser to log in to the internal EnerLog page, as shown in the figure below:



2. Enter the user name and password, the default login user name: admin password: admin, fill in and click to log in.

When the device cannot be used with the router during installation, it can only use a fixed IP to connect to the network, so the first time you enter the built-in page, you need to use the following methods to log in.

After EnerLog is started, you can use this method to log in to the built-in page for the first 2 minutes. If it exceeds 2 minutes, the DHCP function will be automatically enabled.

1. Directly connect the computer and EnerLog with a network cable.
2. On the "Network and Sharing Center" page of the computer, modify the IP address of the computer, The default static IP address of EnerLog is 192.168.0.254, then the computer IP address can be set to:

使用下面的 IP 地址 (S):

IP 地址 (I):

子网掩码 (M):

默认网关 (G):

3. After the computer IP setting is completed, enter the default IP address (192.168.0.254) of EnerLog on the computer browser page to access the built-in page.
4. Refer to chapter 4.6.1, the IP of the fixed EnerLog can be modified, and then only the modified IP can be used to log in. If you forget it, you can reset the EnerLog by referring to Chapter 6.1. Note that the reset will clear all data, so be careful.
5. If you do not modify the fixed IP of EnerLog, you can still use this method to enter the built-in page every time.

4.3 Datalogger status view

Click EnerLog datalogger status, you can view EnerLog "system status information", "serial number", "server address", "number of connected devices" and other information.

As shown in the picture.

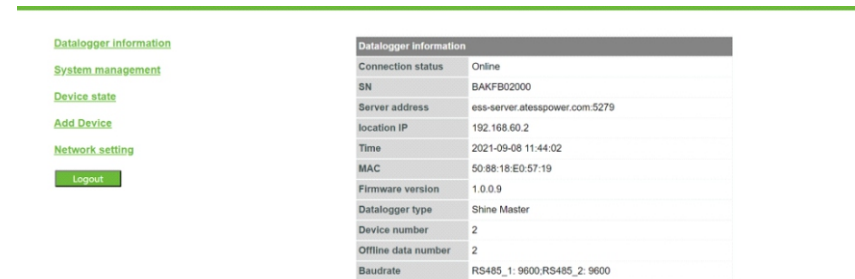

4.4 Add or delete device

Before EnerLog monitors the device, you need to enter the internal page "Add Device" to add the device.

4.4.1 Add device

- (1) Select the type of device in the first drop-down list of "Add or Remove Device", for example, select: ATESS Inverter.

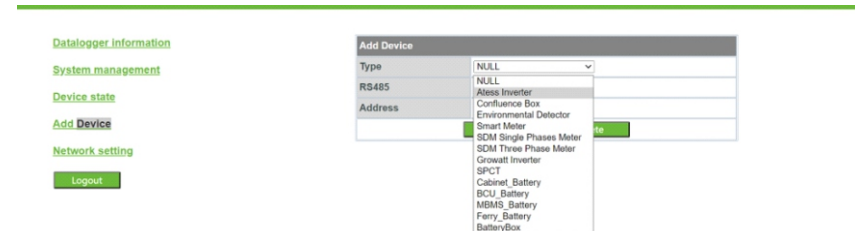

Equipment type description:

ATESS Inverter: HPS, PCS, PBD and other energy storage controllers produced by ATESS.

BCU Battery: BMS system motherboard, one battery rack has one motherboard.

MBMS Battery : BMS system three-layer board, a battery system has only one three-layer board.

(2) Select the 485 channel in the second drop-down list: for example, select: RS485-1.

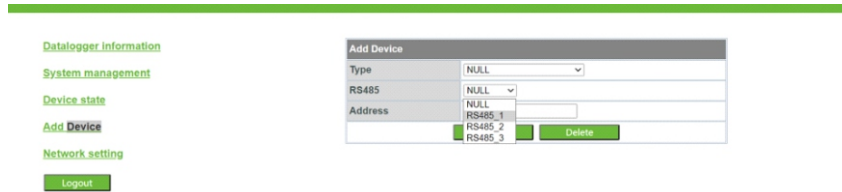

(3) Fill in the communication address of the monitored device in the third list (the communication address should be searched on the monitored device).

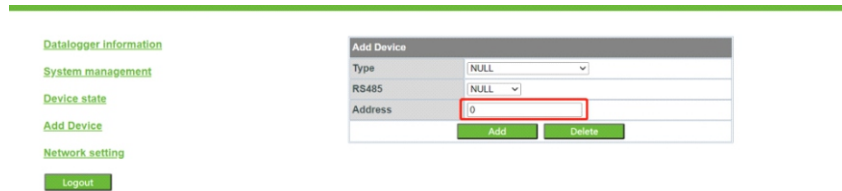

Note: The 485 communication address of all connected devices cannot be repeated.

(4) Select "Add" below and click Save.

(5) After saving successfully, enter the "Device Status" page to confirm whether the device is added successfully.

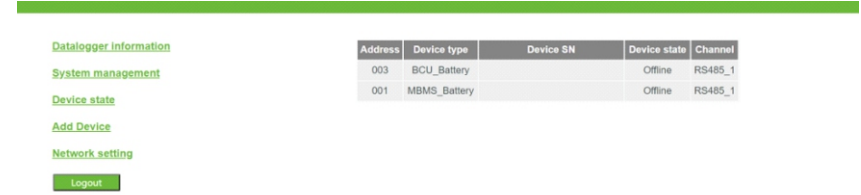

4.4.2 Delete device

(1) Select the type of monitoring device in the first drop-down list of " Add Device ".

(2) Select the 485 channel of the monitored device in the second drop-down list.

(3) Fill in the communication address of the device in the third list.

(4) Select the following "Del" and click Save to complete the deletion of the device.

(5) After saving successfully, enter the device "device status" page to confirm whether the device is deleted successfully.

Notice:

(1) When deleting a device, the options should be the same as when adding the device: 485 channel, device type, address, etc. If you don't know the relevant parameters, you can first click the "Device Status" column to view.

(2) When an address is already occupied, adding a new device will not directly overwrite it. The old device must be deleted before the address can be used.

4.5 Setting the baud rate

The default baud rate of the 485 channel is 9600, and the default baud rate of the equipment produced by ATESS is 9600. If not necessary, please do not modify it.

The modification method is as follows:

(1) Select the baud rate in the "system management" column.

(2) Select the 485 channel to be modified.

(3) Save the modification.

4.6 Network communication

EnerLog communicates through network cable connection. You can choose to automatically allocate IP to the Internet with a DHCP-enabled router, or use a fixed IP to connect to the Internet.

4.6.1 Networking settings

1. Network cable communication

(1) In the "Network setting" page, "DHCP ENABLE" can be set to 0 or 1. 0 means static IP, 1 means DHCP automatically assigns IP.

(2) The DHCP function is enabled by default in the factory, and the IP address is automatically obtained from the router.

(3) If you need to set EnerLog to a static IP during use, you need to make the following settings:

1 Modify the enable to 0, turn off the DHCP function, and modify it to a static IP.

2 Set parameters such as IP, gateway, subnet mask, DNS, etc., and click Save.

5 Upload EnerLog data to the server

5.1 Registration and login

1. Enter the server address on the browser to enter the server login page. If it is the first login, please register first.

The server address is: <http://ess-server.atesspower.com>



2. Click "Account Registration" to enter the account registration page. Register a user name, enter user information according to the prompts, and click "register" after filling in the information.

User

Country

Username No More Than 30 Characters

Password Not Less Than 6 Digits

Password Confirm Not Less Than 6 Digits

Language English

Phone Number

E-Mail

Installer Code

Agree With The Company'S Terms

5.2 Create new power plant

(1) After the account registration is completed, enter the user name and password to log in to the server.

(2) When there are multiple power stations under this account, in order to avoid confusion, you need to create a new power plant before adding EnerLog.

(3) Click "Add Power Plant" at the top right of the main page, and follow the prompts to create a new power station.

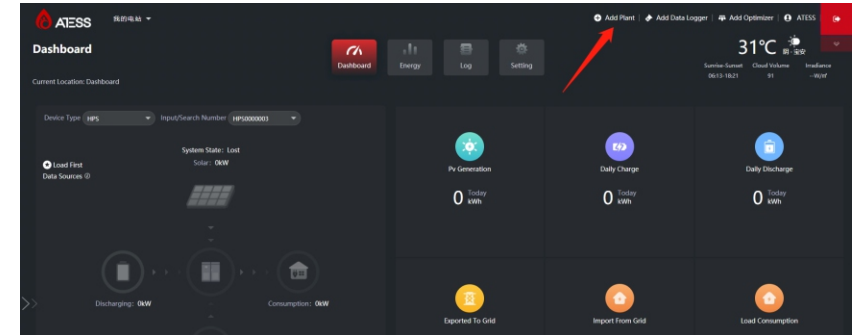

Add Plant

Installation Information

Plant Name Example: David 6.24Wp Plant Installation Date PV Capacity(kWp) Installer

Plant Type Residential Plant

Location Information

Country Please Choose City Address

Time Zone UTC -12 Longitude Latitude Plant Image

Set Revenue Formula(Set 1Kwh As The Conversion Standard)

Selling Price 1.2 RMB(¥) Standard Coal Saved 0.400 Cos Reduced 0.997 Reducing Deforestation 0.055

Electricity price 1.2 Peak Rate 1.3 Standing Rate 1.1 Off-Peak Rate 1.0

5.3 Add EnerLog to the server

(1) After entering the main page of the server, click "Add Collector" in the upper right corner and follow the prompts to add EnerLog.

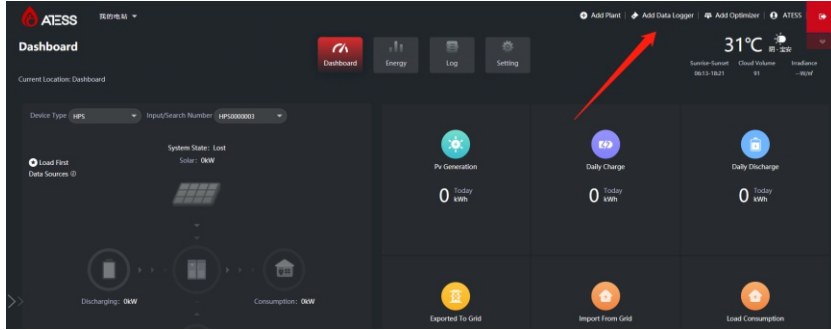

(2) Please find the "collector serial number" and "collector verification code" on the EnerLog outer box or EnerLog shell.

(3) For "Belonging to Power Plant", please select the corresponding power plant.

● Add Data Logger

Data Logger Sn

Check Code

Assigned Plant

Third Party Device

Yes Cancel

5.4 View monitoring data

(1) After successfully adding EnerLog, return to the main page to view the monitoring information.

(2) There are four page selection buttons on the main page, corresponding to different pages.

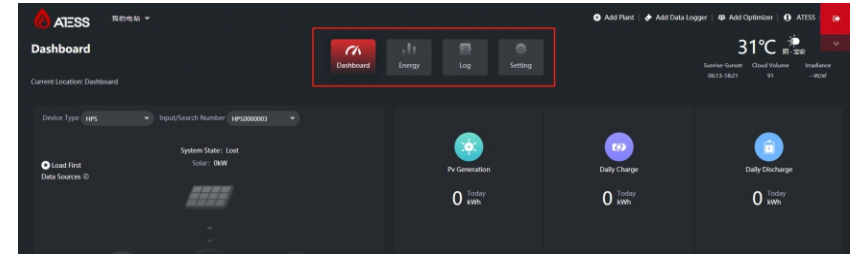

Dashboard: The home page is the "Dashboard" page. Dashboard page display content: equipment real-time accumulated power, power, power and other information, as well as equipment energy trend graphs, battery information, monitoring equipment status and other information.

Energy: The energy page can view the data curve of each monitoring device, including voltage, current, power, battery SOC and other information. And the management of the power station.

Log: The log page can view the historical fault information of all devices.

Settings: Account setting functions, including account password modification, personal information modification and other functions.

You can view and monitor real-time data or historical data on the dashboard page or energy page.

6 Device Maintenance

6.1 Reset EnerLog

1. If the "Reset" button is pressed for more than 1 second, the EnerLog will restart.
2. If you press the "Reset" button for more than 5 seconds, EnerLog will clear all setting information and restore the factory settings. Please proceed with caution.

6.2 Common faults and troubleshooting

Fault	Cause	Suggestion
Cannot enter the EnerLog internal page	EnerLog can not obtain the IP	<ol style="list-style-type: none"> 1.Enable Router DHCP Function 2.PC and the EnerLog must be in the same domain.
EnerLog internal page "System Status Information" shows disconnected	Unable to connect to server	<ol style="list-style-type: none"> 1.Check whether the router network is connected to the Internet. 2.Check if the "server address" is correct <p>The international user server domain is server.atesspower.com.</p>
EnerLog is online, but the monitored device is disconnected after logging in to the account	<ol style="list-style-type: none"> 1.Monitor connection failed 2.No access to the internal page to add equipment 3.Inconsistent Photovoltaic equipment address and added equipment address 4.Illegal PV device serial number 	<ol style="list-style-type: none"> 1.Check the communication line is in contact with the stability 2.Enter the internal page "datalogger settings" to add photovoltaic devices 3.On the "Device Status" page of the internal page, check whether the device's communication address is consistent with the added device. 4.Check whether the serial number of the monitored PV equipment is 10 digits. It can only contain English letters and numbers, and there are no illegal characters.
Long time no refresh interface after operation	Configuration page does not respond	Refresh the page or login in again.

6.3 Maintenance

1. Avoid frequent switching of power supply, handle with care to prevent damage;
2. EnerLog is a product for indoor use, do not place it in humid environments or in direct sunlight.

7 Technical specifications

7.1 EnerLog specification

General specification

Length * width * height	175mm*105mm*31mm
Net Weight	320g

Operating environment

Ambient temperature	-25°C ~ +55°C
Installation	Indoor

Communication

Wireline communication	Rs485 monitors up to 60 devices
RS485 communication distance	Maximum 500 meters (use shielded wire, shielding layer grounded)

8 Contact us

SHENZHEN ATESS POWER TECHNOLOGY CO.,LTD

1st Floor of Building 3 at Sector B and 3rd Floor of Building 9, Henglong Industrial Park, Shuitian,
Baoan District, Shenzhen

www.atesspower.com